

# S2BACLightDP

Aromat /Panasonic/Douglas Lighting Relay Controller

## Introduction

The S2BACLightDP is an intelligent lighting relay controller designed to control twenty-four (24) Panasonic/ Aromat /Douglas Lighting Relays (WR-6221, WR-6161, etc) used primarily in commercial lighting control applications. The S2BACLightDP also provides support for eight (8) configurable Group Inputs, two (2) HVAC and DC Compatible Binary Inputs, along with multiple communication interfaces for standalone and/or integration in the site's Building Management System (BMS).

The S2BACLightDP can be used as a direct replacement to the Douglas Lighting WRS-2224 Scanner that was discontinued by Douglas around 2010. The S2BACLightDP maintains the same form factor and electrical connection locations, and so allows for a very quick and efficient upgrade... about 10 minutes with more features and functionality than the WRS-2224 device.

## Hardware Features

The S2BACLightDP has the following hardware features and functionality:

Part Numbers:	S2BACLightDP-MSTP, S2BACLightDP-BIP S2BACLightDP-DMX, S2BACLightDP-N2 S2BACLightDP-ModbusRTU, S2BACLightDP-ModbusCP
Power Requirements:	24VAC @ 500mA (varies with connected relays and relay states)
Environment:	
Temperature	0 C to +70 C
Humidity	10 – 95 % RH (non-condensing)
Dimensions:	16.4cm L x 10.0cm W x 5.5cm H (6.5"L x 4.0"W x 2.2" H)
Packaging:	Magnetic (standard) or DIN Rail (optional) Mountable
Interfaces:	One (1) 10/100 Mb/s Ethernet Interface One (1) Electrically isolated Half-Duplex RS-485 Interface One (1) DALI – Digital Addressable Lighting Interface (Controller) One (1) High Speed USB Interface

Real Time Clock	On-board Real Time Clock with Battery Backup for local event scheduling. - Support includes automatic calculation of daily sunrise and sunset times (Astrological clock)
Protocols:	BACNet MS/TP and IP, DMX512, JCI N2 Bus, Modbus upon request TCP/IP (Web Services), HTML support, NTP support for automatic time Synchronization, etc
Electrical:	
Outputs:	Twenty-four (24) 2-Wire Bidirectional Pulsed Relays outputs with LED Status Display Outputs are sequentially switched to minimize in-rush load current(s)
Supported Relays:	Panasonic/ Douglas//NexLight/Aromat WR-6221, WR-6161, or equivalent 2-wire relays.
Inputs:	Eight (8) 2-wire Douglas Lighting WR-8xxx or compatible Switch Inputs Each Input is a Programmable Group or Zone allowing control of one or more of the 24 Relay Outputs Two (2) Binary Inputs (12-24V AC/DC or dry contact) Programmable as Maintained, Momentary On or Off One (1) On-board All Relay Override (On or Off) and Relay Test Mode
Building Automation:	Thirty-Two (32) Binary Values (BV) (One BV per Relay and Group Input) Twenty-four (24) Multi-State Inputs (MSI) (One MSI per Relay) Ten (10) Binary Inputs (BI) (One BI per Group and Hardware Inputs) Additional Objects can be added upon request  Eight (8) On-board Time Schedules - Controlling any combination of Relay Outputs - Schedules can be based upon: Day of week Fixed times Fixed time with on/off repeat interval (e.g. on/off sweeps) Fixed time with off only repeat interval (e.g. off sweeps) Triggered On With off repeat interval (e.g. on/off sweeps) Daily Sunrise and Sunset Times

## S2BACLIGHTDP - Bacnet Object Map

Object	Name	Type	Values
BI0	Group_Status01	Binary	0 = Off, 1 = On
BI1	Group_Status02	Binary	0 = Off, 1 = On
BI2	Group_Status03	Binary	0 = Off, 1 = On
BI3	Group_Status04	Binary	0 = Off, 1 = On
BI4	Group_Status05	Binary	0 = Off, 1 = On
BI5	Group_Status06	Binary	0 = Off, 1 = On
BI6	Group_Status07	Binary	0 = Off, 1 = On
BI7	Group_Status08	Binary	0 = Off, 1 = On
BI8	BI-00	Binary	0 = Off, 1 = On
BI9	BI-01	Binary	0 = Off, 1 = On
BV0	Relay01	Binary	0 = Off, 1 = On
BV1	Relay02	Binary	0 = Off, 1 = On
BV2	Relay03	Binary	0 = Off, 1 = On
BV3	Relay04	Binary	0 = Off, 1 = On
BV4	Relay05	Binary	0 = Off, 1 = On
BV5	Relay06	Binary	0 = Off, 1 = On
BV6	Relay07	Binary	0 = Off, 1 = On
BV7	Relay08	Binary	0 = Off, 1 = On
BV8	Relay09	Binary	0 = Off, 1 = On
BV9	Relay10	Binary	0 = Off, 1 = On
BV10	Relay11	Binary	0 = Off, 1 = On
BV11	Relay12	Binary	0 = Off, 1 = On
BV12	Relay13	Binary	0 = Off, 1 = On
BV13	Relay14	Binary	0 = Off, 1 = On
BV14	Relay15	Binary	0 = Off, 1 = On
BV15	Relay16	Binary	0 = Off, 1 = On
BV16	Relay17	Binary	0 = Off, 1 = On
BV17	Relay18	Binary	0 = Off, 1 = On
BV18	Relay19	Binary	0 = Off, 1 = On
BV19	Relay20	Binary	0 = Off, 1 = On
BV20	Relay21	Binary	0 = Off, 1 = On
BV21	Relay22	Binary	0 = Off, 1 = On
BV22	Relay23	Binary	0 = Off, 1 = On
BV23	Relay24	Binary	0 = Off, 1 = On
BV24	Group01	Binary	0 = Off, 1 = On
BV25	Group02	Binary	0 = Off, 1 = On
BV26	Group03	Binary	0 = Off, 1 = On
BV27	Group04	Binary	0 = Off, 1 = On
BV28	Group05	Binary	0 = Off, 1 = On
BV29	Group06	Binary	0 = Off, 1 = On
BV30	Group07	Binary	0 = Off, 1 = On
BV31	Group08	Binary	0 = Off, 1 = On
MSI0	Relay_Status01	Multistate	1 = On, 2=Off, 3=Fault, 4=Absent
MSI1	Relay_Status02	Multistate	1 = On, 2=Off, 3=Fault, 4=Absent
MSI2	Relay_Status03	Multistate	1 = On, 2=Off, 3=Fault, 4=Absent
MSI3	Relay_Status04	Multistate	1 = On, 2=Off, 3=Fault, 4=Absent
MSI4	Relay_Status05	Multistate	1 = On, 2=Off, 3=Fault, 4=Absent
MSI5	Relay_Status06	Multistate	1 = On, 2=Off, 3=Fault, 4=Absent

MSI6	Relay_Status07	Multistate	1 = On, 2=Off, 3=Fault, 4=Absent
MSI7	Relay_Status08	Multistate	1 = On, 2=Off, 3=Fault, 4=Absent
MSI8	Relay_Status09	Multistate	1 = On, 2=Off, 3=Fault, 4=Absent
MSI9	Relay_Status10	Multistate	1 = On, 2=Off, 3=Fault, 4=Absent
MSI10	Relay_Status11	Multistate	1 = On, 2=Off, 3=Fault, 4=Absent
MSI11	Relay_Status12	Multistate	1 = On, 2=Off, 3=Fault, 4=Absent
MSI12	Relay_Status13	Multistate	1 = On, 2=Off, 3=Fault, 4=Absent
MSI13	Relay_Status14	Multistate	1 = On, 2=Off, 3=Fault, 4=Absent
MSI14	Relay_Status15	Multistate	1 = On, 2=Off, 3=Fault, 4=Absent
MSI15	Relay_Status16	Multistate	1 = On, 2=Off, 3=Fault, 4=Absent
MSI16	Relay_Status17	Multistate	1 = On, 2=Off, 3=Fault, 4=Absent
MSI17	Relay_Status18	Multistate	1 = On, 2=Off, 3=Fault, 4=Absent
MSI18	Relay_Status19	Multistate	1 = On, 2=Off, 3=Fault, 4=Absent
MSI19	Relay_Status20	Multistate	1 = On, 2=Off, 3=Fault, 4=Absent
MSI20	Relay_Status21	Multistate	1 = On, 2=Off, 3=Fault, 4=Absent
MSI21	Relay_Status22	Multistate	1 = On, 2=Off, 3=Fault, 4=Absent
MSI22	Relay_Status23	Multistate	1 = On, 2=Off, 3=Fault, 4=Absent
MSI23	Relay_Status24	Multistate	1 = On, 2=Off, 3=Fault, 4=Absent
IV1	Time On Minutes	Integer Value	Read Only – Time On in Minutes
IV2	Restart Request	Integer Value	Write 54321 results in restart
IV3	Reset Reason	Integer Value	Read Only – Last Restart Coded Reason
IV4	Current Time	Integer Value	Read Only – Device Time
IV5	Current MonthDay	Integer Value	Read Only – Current MonthDay
IV6	Bitfield Relay Status	Integer Value	Read Only – Bitfield Relay States
IV7	Bitfield Relay Cmd On	Integer Value	Do not Use
IV8	Bitfield Relay Cmd Off	Integer Value	Do not Use

Additional Bacnet Objects can be added upon request.

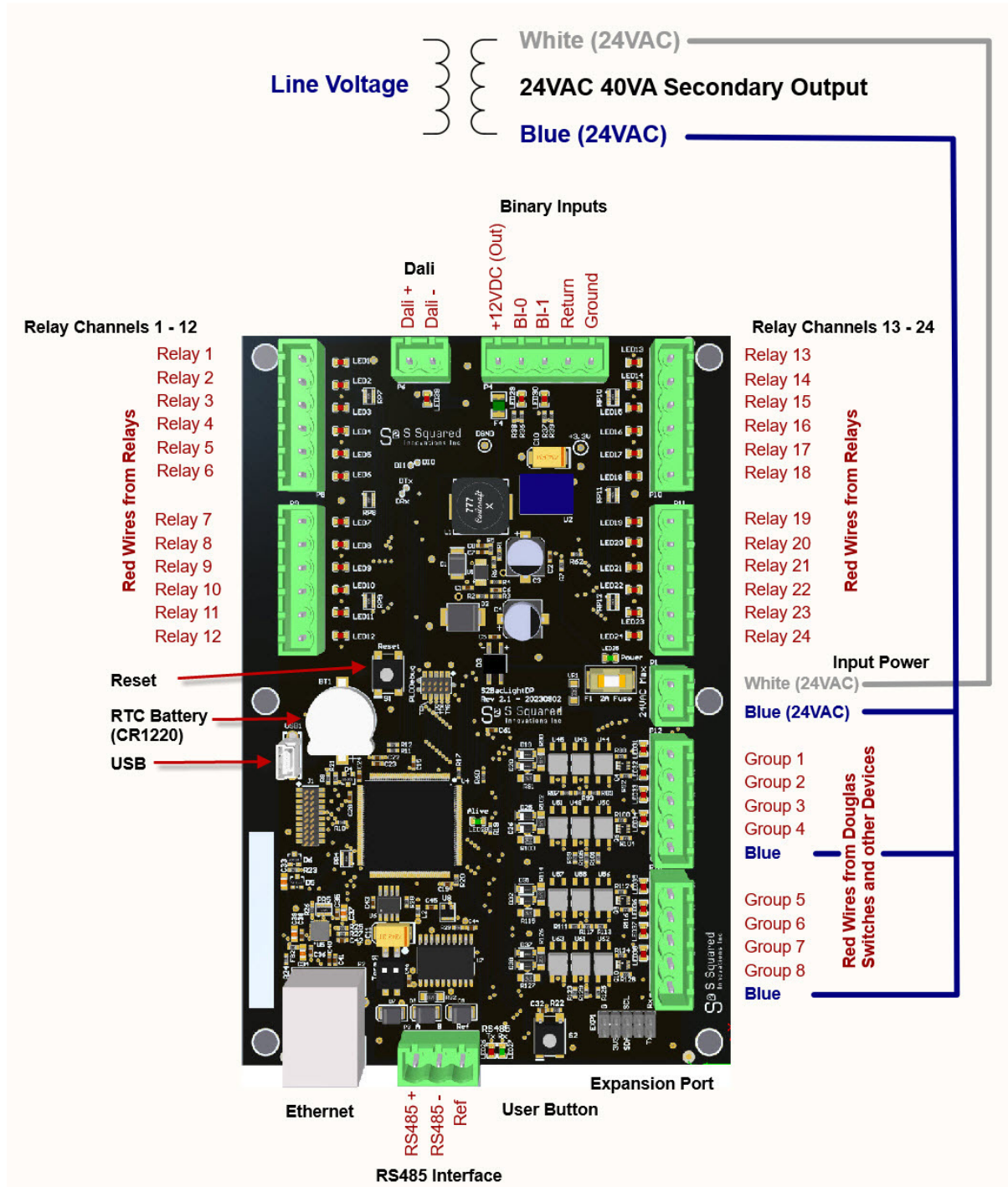

**S2BACLightDP Controller Connections**